



INSTRUCTIONS FOR USE

DESCRIPTION OF THE APPLIANCE

BEFORE USING THE REFRIGERATOR

INSTALLATION

HOW TO OPERATE THE REFRIGERATOR/FREEZER

GUIDE TO FOOD STORAGE

**USE OF THE ICE AND WATER DISPENSER
(ON SOME MODELS)**

**USE OF THE DISPENSER LIGHT AND DISPENSER LOCK
(ON SOME MODELS)**

AUTOMATIC ICE MAKER

COMMON ICE MAKER PROBLEMS

MAINTENANCE AND CLEANING

VACATION

TROUBLESHOOTING GUIDE/SERVICE

**WATER FILTRATION AND MONITORING SYSTEM
(ON SOME MODELS)**

WATER CONNECTION

DISPOSAL OF YOUR OLD REFRIGERATOR

ELECTRICAL CONNECTION

DESCRIPTION OF THE APPLIANCE

The model you have purchased may have all or some of the parts and features shown and they may not match the illustration exactly. This manual covers several models.

MODEL TYPE I

with ice/water dispenser

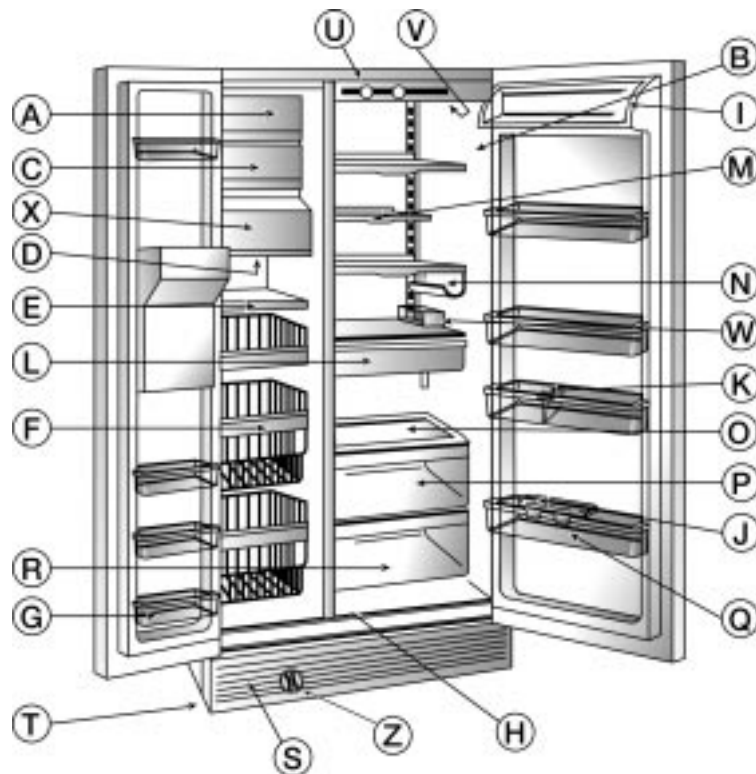

Freezer Compartment

- A - Top freezer compartment (on some models)
- C - Automatic ice maker
- D - Inside light
- E - Pull-out shelf (the number depends on the model)
- F - Deep baskets (the number depends on the model)
- G - Stationary door bins
- X - Ice bin

Refrigerator Compartment

- B - Rating plate
- H - Meat / vegetable drawer temperature control
- I - Butter compartment with butter tray
- L - Snack bin (on some models)
- M - Adjustable shelf (on some models)
- J - Tall bottle retainer (on some models)
- K - Bottle safety support

- N - Bottle holder
- O - Fruit and vegetable drawer lid
- P - Fruit and vegetable drawer with moisture control
- Q - Adjustable door bins
- R - Meat / vegetable drawer
- S - Front grille
- T - Defrost pan
- U - Control panel
- V - Inside light
- W - Egg container (tray and bucket)
- Z - Water Filter (on some models)

Control panel

- Temperature control slider – freezer compartment
- Temperature control slider – refrigerator compartment

DESCRIPTION OF THE APPLIANCE

MODEL TYPE II
without ice/water dispenser

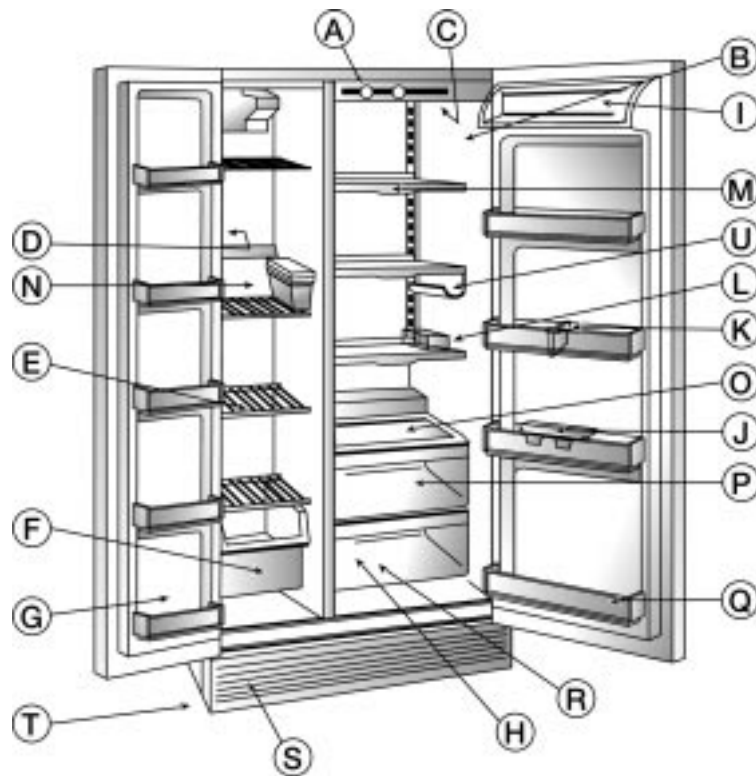

Freezer Compartment

- D - Inside light
- E - Shelf (the number depends on the model)
- F - Deep shelves (the number depends on the model)
- G - Stationary freezer door shelves
- N - Ice cube trays (Ice maker optional)

Refrigerator Compartment

- A - Control panel
- B - Rating plate
- C - Inside light
- H - Meat / vegetable drawer temperature control
- I - Butter compartment with butter tray
- L - Egg container (tray and bucket - on some models)
- J - Tall bottle retainer (on some models)

- K - Bottle safety support (on some models)
- M - Stationary shelf
- O - Fruit and vegetable drawer lid
- P - Fruit and vegetable drawer with moisture control
- Q - Stationary door shelves
- R - Meat / vegetable drawer
- S - Front grille
- T - Defrost pan
- U - Bottle holder (on some models)

Control panel

- Temperature control dial - freezer compartment
- Temperature control dial - refrigerator compartment

BEFORE USING THE REFRIGERATOR

- After unpacking, make sure that the appliance is undamaged and that the door closes perfectly tight. Any damage must be reported to your retailer within 24 hours after delivery of the appliance.
- The packaging box is recyclable and is marked with the recycling symbol .
- The appliance is built with reusable material. When scrapping, follow the local environment protection disposal regulations. To avoid the risk of children being trapped and therefore suffocating, do not allow them to play or hide inside the refrigerator. Render the refrigerator inoperative by removing the doors and cutting the power cable off. Do not dump the appliance. Take it to the local disposal centre so that the refrigerant may be properly recovered and treated.
- Make sure that the installation and the electrical connection are carried out by a qualified technician according to the manufacturer's instructions and local safety regulations.

Declaration of conformity

- This appliance is designed to store food and is manufactured in conformity with EEC directive No. 89/109.
- This appliance has been designed, built, and marketed in compliance with:
 - the safety targets of the Low Voltage EEC Directive 73/23;
 - the protection requirements of the "EMC" EEC Directive 89/336 amended by EEC Directive 93/68.
- This appliance is free of CFC's (refrigerant circuit contains R134a). For more details, please refer to the rating plate on the appliance.

Precautions and general suggestions

- Use the refrigerator compartment only for the storage of fresh food and the freezer compartment only for the storage of frozen food, the freezing of fresh food, and to make ice cubes.
- After installation, make sure that the refrigerator does not stand on the power cable.
- Do not store glass containers with liquids in the freezer since they may burst.
- Do not eat ice cubes or ice lollies immediately after taking them out of the freezer since they may cause "cold" burns.
- Before carrying out any maintenance or cleaning, always unplug the appliance or disconnect the power supply.
- Do not store or use gasoline or other flammable vapours and liquids in the vicinity of this or any other appliance. The fumes can create a fire hazard or explosion.



INSTALLATION

- Make sure that your refrigerator is not near a heat source.
- Place it in a dry and well ventilated room.
- To ensure proper ventilation leave a 1.25 cm space on both sides and at the top of the refrigerator.
- Clean the inside of the refrigerator before using it.
- Let the refrigerator stand (don't move it) for at least one hour before connecting it to the power supply.
- The ice maker should be connected to a water supply that delivers drinkable or chemically purified water.
- Install and level the refrigerator on a floor that will hold the weight and in an area suitable for its size and use.
- Do not use the refrigerator in an area where the room temperature will fall below 13°C.

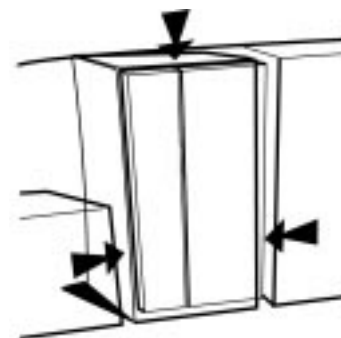



INSTALLATION (FOR 60 cm DEEP MODELS ONLY)

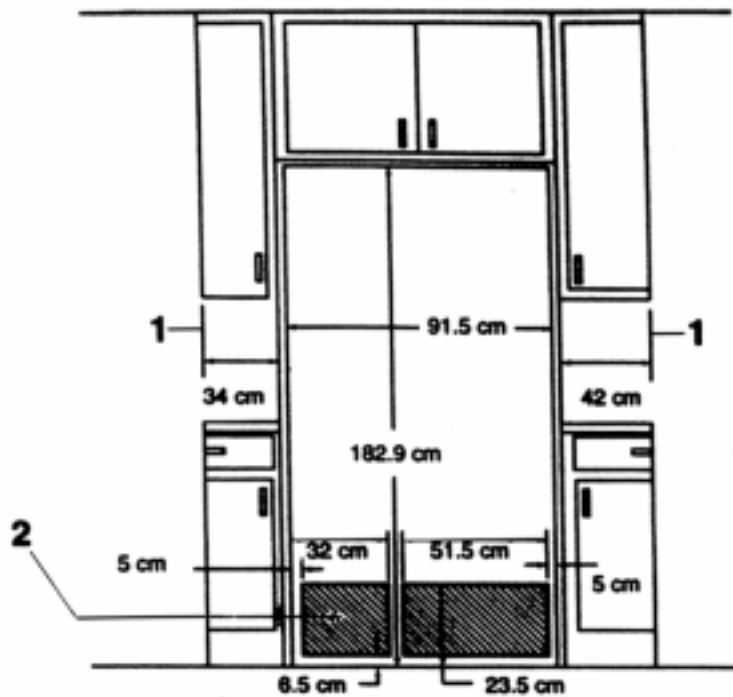

1. Minimum fixed wall position.
 2. Recommended locations for electrical and water connections.
 3. For full-overlay cabinet doors and a trim kit, the height of the opening must be 183.2 cm.
- If you are installing the refrigerator to fit flush with the front of the base cabinets, all shoe molding and baseboards must be removed from the rear of the refrigerator opening.
 - The water hookup and electrical hookup must be placed near the bottom of the refrigerator.
 - A trim kit is available for those installations where the refrigerator will not fit flush. See the "Assistance or Service" section for ordering information.
- NOTE:** Do not install the refrigerator near an oven, radiator or other heat source, nor in a location where the temperature will fall below 55°F (13°C).

INSTALLATION (FOR 60 cm DEEP MODELS ONLY)

Custom Door Panels

Creating Custom Wood Panels

If you plan to install custom wood decorator panels, you will need to create the panels yourself or consult your cabinet maker or carpenter. See dimensional drawings for wood panel inserts.

Flat panels:

You can create a custom flat panel a maximum of 6.35 mm thick to replace your decorator panels. Flat wood panels less than 6.35 mm thick are not recommended.

Raised panels:

A raised panel design can be created by screwing or gluing wood panels to 6.35 mm backing or by using 19.05 mm stock with routed edges. Raised panels should be spaced 5.70 cm from the back edge of the handle to allow room for fingers to grasp the handle.

Weight requirements for raised panel inserts:

- Refrigerator door panel should not exceed 12.7 kg.
- Freezer door panels should not exceed 9.5 kg combined weight.

Dimensions for custom wood panels:

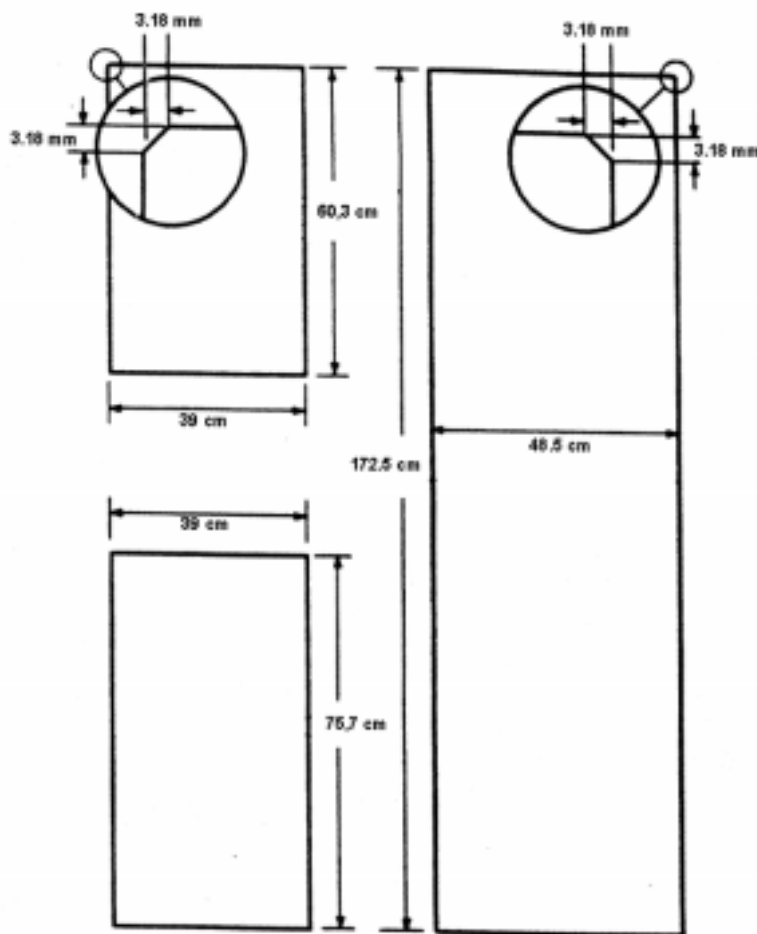



INSTALLATION (FOR 60 cm DEEP MODELS ONLY)

Installing Custom Wood Panels

1. Remove any packing tape.
2. Remove the refrigerator and freezer door trims from the hinge side of each door by pulling the trim away from the bottom of the door first.
3. Partially unscrew the two screws that hold the top trim in place. It is not necessary to completely remove the screws. Loosen the screws approximately 6.35 mm from the trim to allow the panels to slide freely.
4. Remove the existing door panels, if panels were provided.
5. Slide custom door panels into place.

NOTE: The freezer door panels may require 3.18 mm cardboard fillers behind the panels to keep them from being loose in that area.
6. Replace the hinge side trims by inserting the notched end under the top trim first.
7. Tighten the two top trim screws.

To remove the base grille:

1. Open the refrigerator and freezer doors 90°.
2. Remove screws from the base grille using a screwdriver.

NOTE: Do Not Remove Tech Sheet that is fastened behind the base grille.

To replace the base grille:

1. Open the refrigerator and freezer doors to 90°.
2. Position the base grille in front of the refrigerator and replace the screws.

Leveling Your Refrigerator

Your refrigerator has a front and rear roller at the base of the product on each side. All four rollers can be adjusted from the front of the product. If your refrigerator seems unsteady or you want the doors to close easier, adjust the refrigerator's tilt using the instructions below:

1. Check the installation location to be sure that you have the proper clearance for the refrigerator. (See the "Space Requirements" section.)
2. Plug into a grounded 3 prong outlet.
3. Move the refrigerator into its final position.
4. Open the refrigerator and freezer doors to locate the leveling bolts at the left and right of the refrigerator base. If your refrigerator has a base grille, remove it (see "Base Grille" earlier in this section).

- NOTE:** The top bolt will adjust the rear of the refrigerator, and the bottom bolt will adjust the front of the refrigerator.
5. Use a 12.70 mm socket wrench to adjust the leveling bolts. Turn the leveling to the right to raise that side of the refrigerator or turn the leveling bolt to the left to lower that side. It may take several turns of the leveling bolts to adjust the tilt of the refrigerator.

NOTE: Be careful not to unscrew the leveling bolts too much when lowering the refrigerator. The bolt head will start to come away from the refrigerator when in the lowest position. If the screw does come out of the rear roller bracket, the compartment access cover on the back of the refrigerator will have to be removed to reinstall the bolt.

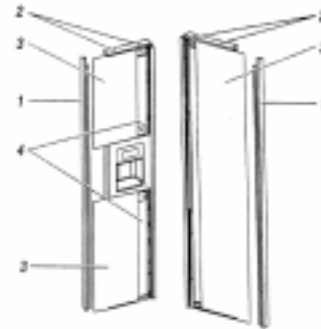

1. Side Trims
2. Top Trim Screws
3. Door Panels
4. Filler Panels

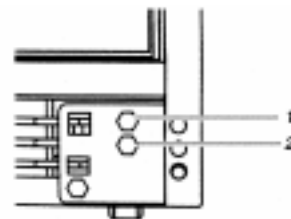

1. Rear Leveling Bolt
2. Front Leveling Bolt

INSTALLATION (FOR 60 cm DEEP MODELS ONLY)

6. Adjust the front leveling bolt to bring the refrigerator top parallel with the cabinet above the refrigerator. Leave approximately 3.18 mm gap between the top hinges and the cabinet. If you do not have a cabinet above the refrigerator, simply adjust the refrigerator to make it level.
7. Adjust the rear leveling bolt to bring the refrigerator level with the side cabinets or cabinet end panels.
8. If you want, you may now use the four leveling bolts to raise the refrigerator to close the gap between the refrigerator top hinge and the cabinet opening. Check that all four rollers still touch the floor and that the cabinet doors above the refrigerator open all the way.

NOTE: Cabinets with full-overlay doors will require 6.35 mm additional clearance between the top hinge and cabinet to prevent the doors from hitting the hinge when opening. If you have a trim panel kit on the refrigerator doors, 19.05 mm additional clearance is needed to prevent the cabinet doors from hitting the refrigerator door trim.

9. Replace the base grille.

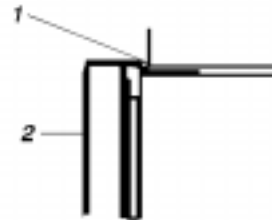

1. Leave 3.18 mm minimum clearance for leveling the refrigerator. Leave 6.35 mm minimum clearance if you have full-overlay cabinet doors.
2. Front of the refrigerator.

INSTALLATION (FOR ALL MODELS GREATER THAN 60 cm DEEP)

Leveling

If necessary, it is possible to level the appliance from side to side by turning the two levelling screws right behind the front grille on the refrigerator bottom, one on the right and the other on the left, proceeding as follows:

- remove the front grille;
- turn one screw or both, clockwise to raise the appliance;
- turn one screw or both, anticlockwise to lower the appliance;
- check if the desired levelling has been reached;
- put the front grille back into place.

Removal of the front grille

To remove the grille:

- open both doors (refrigerator and freezer);
 - pull out the grille frontally to release it from the metal retainers.
- At this point it is possible to reach the defrost pan for periodic cleaning, proceeding as follows:
- remove the defrost pan;
 - wash the defrost pan with warm water and sodium bicarbonate;
 - rinse and dry;
 - put the defrost pan back into place with the notched corner to the rear;
 - make sure that the defrost drain tube is pointing into the pan;
 - put the front grille back into place.

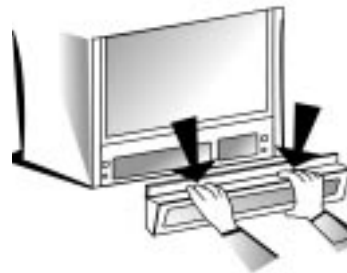

HOW TO OPERATE THE REFRIGERATOR/FREEZER

1. Temperature control (sliders) (Fig. 1)

When the appliance is used for the first time, set the refrigerator and freezer temperatures on the intermediate position (small triangle); to change these values, move the sliders either left or right: to the **left** for a **less cold** temperature, to the **right** for a **colder** temperature.

2. Water filter control (on some models) (Fig. 2)

When the **water indicator light** is **green** it means that the filter is good.

When the light turns into **yellow** it is time to order a new filter.

When the light is **red** the water filter must be changed.

To **reset** the filter indicator to green, push light switch 5 times in 10 seconds.

3. Temperature control (thermostat knobs) (Fig. 3)

The knobs for refrigerator and freezer temperature control are inside the refrigerator. When the appliance is used for the first time:

- set the refrigerator temperature control knob on position 3. It is possible to set the refrigerator temperature from position 1 (less cold) to position 5 (colder);
- set the freezer temperature control knob on position B. It is possible to set the freezer temperature from position A (less cold) to position C (colder) from the very beginning or whenever temperature needs to be changed.

The appliance needs time for the set temperatures to stabilize, so wait before putting food inside.

The mid-range temperature setting recommended in this example is the right one for normal household purposes.

How to turn the appliance off:

Move the freezer temperature control slider or the refrigerator temperature control knob, to the **OFF / ON** position; this operation turns refrigeration off in both the freezer and the refrigerator compartments.

NOTE: remember that this operation **does not disconnect** the appliance from the power supply.

A built-in exterior moisture control continuously guards against moisture build-up on the outside edges of the refrigerator cabinet.

Do not be alarmed, if these edges sometimes feel warm to the touch.



Fig. 1



Fig. 2

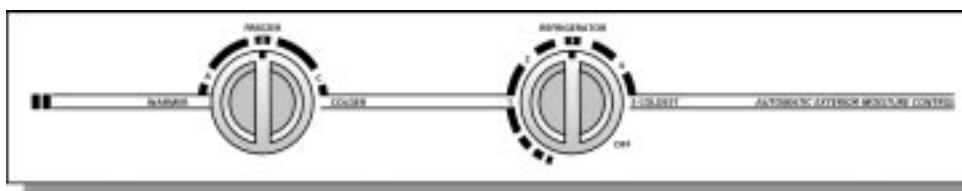

Fig. 3

HOW TO OPERATE THE REFRIGERATOR/FREEZER

4. Setting the electronic controls (Fig. 4)

Give your refrigerator the time to cool down completely before adding food. It is best to wait 24 hours before you put food into the refrigerator.

IMPORTANT: If you add food before the refrigerator has cooled completely, your food may spoil. Turning the Refrigerator and Freezer Controls to a cooler than recommended setting will not cool the compartments any faster.

The Refrigerator Control adjusts the refrigerator compartment temperature. Press the up arrow to make the temperature warmer. Press the down arrow to make the temperature colder.

The Freezer Control adjusts the freezer compartment temperature. Press the up arrow to make the temperature warmer. Press the down arrow to make the temperature colder.

The Power Control Turns off the refrigerator's temperature control. Press the Power Control button.

NOTE: Your product **will** not cool when the Power Control is set to OFF.

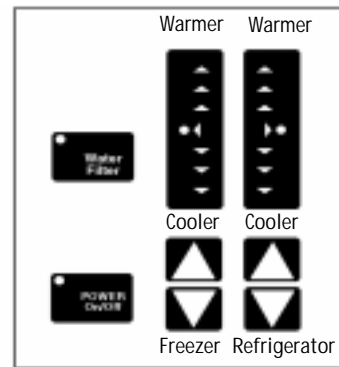

Fig. 4

Removal and rearrangement of the adjustable door bins

Position the door bin according to your needs.

To remove the door bin:

- lift the door bin;
- pull it straight out.

To reposition the door bin:

- repeat above in reverse order.

Removal of the lower shelf on refrigerator and freezer doors

To allow for easy cleaning, it is possible to remove the toeboard indicated in the drawing by pushing the two ends of the toeboard, and pulling out.

To put the toeboard back:

- align the two ends of the toeboard above the side pockets of the door;
- press the toeboard down until it snaps into position.

Removal of the snack bin and its lid

- To remove the snack bin:
- slide the snack bin out until it stops;
- raise the front side of the bin to a 45° angle;
- slide the bin completely out.

To reposition it, carry out the above operations in reverse order.

To remove the lid:

- raise the front side of the lid and then the back side;
- pull outwards.

To reposition, carry out the above operations in reverse order.

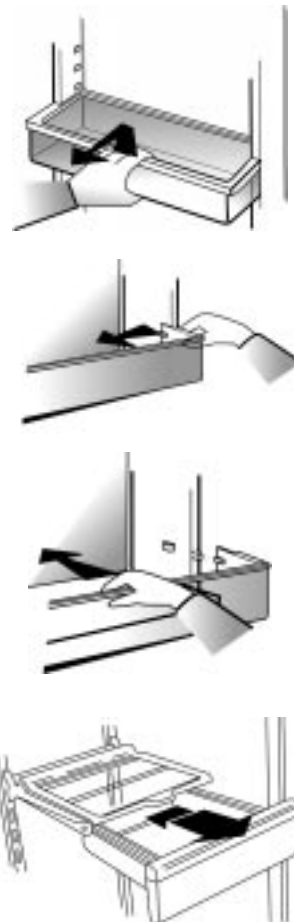

HOW TO OPERATE THE REFRIGERATOR/FREEZER

Use of the hanging bottle holder

This bottle holder can accommodate 1 bottle: hang it under the right or left side of any refrigerator shelf.

Removal and rearrangement of the refrigerator shelves

It is possible to position the shelves according to your needs. The glass shelves are strong enough to hold bottles, milk cartons and heavy food: however, please don't bang them on the shelves.

To remove the shelves:

- lift the front 10 cm;
- with one hand underneath, lift the back of the shelf;
- with both hands, pull shelf straight out.

Removal of the fruit and vegetable drawer and its cover, OR

Removal of the meat drawer and its cover:

- slide the drawer out until it stops;
- with one hand underneath the drawer, lift the drawer and pull-out;
- the drawer will fall from the rails and can be pulled out further;
- to remove completely, the drawer will need to be rotated: front end up, back end down.

To remove the glass cover of the drawer

- first remove the meat drawer and the fruit and vegetable drawer as described above;
- then, with one hand underneath, lift and remove the glass cover from its frame.

The frame of the cover can also be removed:

- lift the front of the frame 10 cm, then;
- with your other hand, lift the back of the frame, and pull-out.

To put the cover back:

- insert the back of the frame in the supports on the refrigerator walls;
- lower it back into place;
- replace the glass cover.

Meat drawer temperature control

The cold air flows inside the meat drawer through an opening between the refrigerator and the freezer compartment. This helps to keep the meat drawer colder than the rest of the refrigerator. Set the slider for higher or lower airflow.

Vegetable Position

If you wish to store vegetables in the meat drawer, move the control all the way to the left to the vegetables setting. (This avoids possible frost of the vegetables).



HOW TO OPERATE THE REFRIGERATOR/FREEZER

Half-width flip-up shelf (on some models)

To raise and lower the shelf:

1. Raise the shelf by first sliding it back and down to make it half-width. (You can use the shelf in this position to allow taller items to be stored on the shelf below).
2. Lift the front of the shelf until it fits securely in place against the back wall.
3. Lower the shelf securely back into position.
4. Pull the front of the shelf forward until it fits into place.

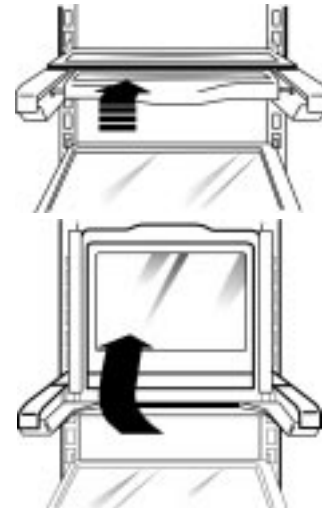

Fruit and vegetables drawer moisture control

It is possible to control the moisture in the fruit and vegetable drawer:

- the control may be set in any position from LOW to HIGH.
- LOW excludes damp air from the drawer for better preservation of fruits and vegetables with peel.
- HIGH keeps damp air inside the drawer for better preservation of leafy vegetables.



Removal of the freezer compartment shelf

To remove the shelf:

- lift the right side from the supports;
- slide the shelf out of the supports on the left;
- put it back proceeding in reverse order.

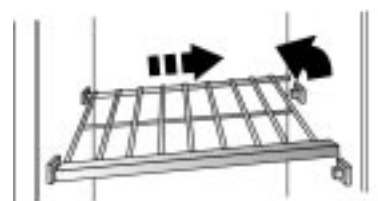

Removal of the freezer compartment deep shelves

- slide the deep shelf outwards until it stops;
- lift the front to release the deep shelf from the retainer;
- pull out the deep shelf completely.



GUIDE TO FOOD STORAGE

The freezer compartment, marked with the symbol , allows the storage of frozen food as well as the freezing of fresh or cooked food. It also allows the making of ice cubes.

Freezing

The maximum quantity of food which can be frozen in a 24 hour period, at an ambient temperature of 25°C, is stated on the rating plate, inside the refrigerator.

Set the "FREEZER" control knob of the freezer compartment to its coldest setting.

Freezing of fresh food and automatic ice making cannot be carried out at the same time.

Therefore do not forget to stop the automatic ice maker by setting the lever on OFF. See the operating instructions in chapter "Automatic ice maker".

Do not store warm food in the freezer; do not refreeze already thawed food; it is possible to freeze it after cooking. Wrap food in aluminium foil or plastic film or place it into appropriate containers. Label the wrappings and mark the freezing date and the contents.

The freezer compartment maintains the adequate storage temperature even during a power failure, for a period of approximately 6 hours. However, during this time, we suggest you leave the freezer door closed.

Preparing fresh food for freezing

It is important to wrap food so that no water, moisture, or vapour may pass through; this avoids the transfer of odour or flavour throughout the refrigerator and allows better storage of frozen food.

We recommend the use of plastic containers with tight fitting lids, aluminium trays, aluminium foil, plastic film, and waterproof plastic wrappings.

Sealing

When sealing the food in bags, squeeze out the air (liquids need head space to allow for expansion).

Fasten the top of the bag with a string. Put the label inside transparent bags; use self-adhesive labels on the outside of opaque ones.



GUIDE TO FOOD STORAGE

Freezing fruit

Select ripe, blemish-free fruit. Clean, peel and slice as needed. Pack in rigid containers or other recommended material. Leave some head space to allow liquid to expand during freezing.

Freezing vegetables

For best results freeze no more than 2 to 3 hours after picking. Wash in cold water, clean and cut as needed. Blanch. Pack in recommended containers and freeze.

Do not freeze lettuce, celery, carrot sticks, potatoes, or fresh tomatoes. All will become limp or mushy. Tomatoes will collapse when thawed.

Freezing meat

Thawed meat will be as good as before freezing.

Steaks or flat cuts should be wrapped individually or in layers separated by a double sheet of freezer wrap.

Freezing cooked food

Cook your food as you would for the table: shorten the cooking time 10 to 15 minutes to allow for additional cooking during reheating. Do not season and remove part of the cooking liquid. Remember to add them when reheating.

Cool as rapidly as possible and freeze at once.

Liquid or semi-liquid dishes must be frozen in recommended containers leaving some head space to allow for expansion. Casseroles and other more solid food can be frozen in oven proof containers.

Freezing pastry and bread

Wrap bread in recommended material. Thaw inside the wrapping. Unbaked yeast bread can be frozen after the first rising. Punch down, wrap, and freeze.

Bake cookies and pastry as usual. Cool and freeze on trays, then pack in recommended freezer bags or cartons. Unbaked cookies and pastry may be dropped, moulded, or rolled and frozen on trays. Store in bags or cartons. Bake without thawing.

Fruit pies are best frozen unbaked. Bake without thawing.



GUIDE TO FOOD STORAGE

Food storage chart

Storage time will vary according to the quality of the food, the type of packaging or wrap used (moisture and vapour proof), and the storage temperature (which should be -18°C).

FOOD

STORAGE TIME

FRUIT

Fruit juice concentrate	12 months
Fruit (general)	8 to 12 months
Citrus fruit and juice	4 to 6 months

VEGETABLES

Commercially frozen	8 months
Home frozen	8 to 12 months

MEAT

Sausages	4 weeks or less
Hamburgers	1 month
Beef, veal, lamb	2 to 3 months

Roasts

Beef	6 to 12 months
Lamb and veal	6 to 12 months
Pork	4 to 8 months
Fresh sausage	1 to 2 months

Steaks and chops

Beef	8 to 12 months
Lamb, veal, pork	2 to 4 months

FISH

Cod, flounder, sole	6 months
Salmon	2 to 3 months
Mackerel, perch	2 to 3 months
Battered fish (purchased)	3 months
Clams, oysters, cooked fish, crab	3 to 4 months
Raw shrimp	12 months

Thawing

Here are some helpful hints:

Raw vegetables: do not thaw, put straight into boiling water and cook as usual.

Meat (large cuts): thaw in the refrigerator compartment without unwrapping. Before cooking, leave at room temperature for a couple of hours.
(small cuts): thaw at room temperature or cook directly.

Fish: thaw in the refrigerator compartment without unwrapping or cook directly before complete thawing.

POULTRY

Chicken or turkey (whole or parts)	12 months
Duck and goose	6 months
Giblets	2 to 3 months
Cooked poultry with gravy	6 months
Cuts (no gravy)	1 month

STEWES

Meat, poultry, and fish	2 to 3 months
-------------------------	---------------

DAIRY PRODUCTS

Butter	6 to 9 months
Margarine	12 months

Cheese

Camembert, mozzarella, cottage	3 months
Creamy cheeses	do not freeze
Brie, Emmenthal, Suisse, etc.	6 to 8 weeks
(Freezing may alter cheese texture)	
Ice cream, fruit juices, milk	12 months

EGGS

Whole (beaten), whites, yolks	12 months
(Add sugar or salt to yolks or whole beaten eggs)	

PASTRY AND BREAD

Yeast bread and rolls	3 months
Unbaked bread	1 month
Croissants	3 months
Cakes (unfrosted)	2 to 4 months
Cakes (frosted) and baked cookies	6 to 12 months
Fruit pies	12 months
Cookie dough	3 months
Pie dough	4 to 6 months

We remind you that, in case of power failure, the freezer compartment maintains the appropriate storage temperature for approximately 12 hours; during this time, we suggest you leave the door of the compartment closed. Do not refreeze partially thawed food.

Previously cooked food: reheat in the oven without removing it from its aluminium container.

Fruit: thaw in the refrigerator compartment.

NOTE: Never store warm food in the freezer.

Allow hot foods to cool to room temperature for 30 minutes, then package and freeze. Cooling hot foods before freezing saves energy and prolongs the life of the appliance.

USE OF THE ICE AND WATER DISPENSER (ON SOME MODELS)

Your freezer dispenses both cubed and crushed ice. Before dispensing ice, select which type of ice you prefer. The button controls are designed for easy use and cleaning.

For cubed ice, press the cubed ice button until the red indicator appears in the window above the button. For crushed ice, press the crushed ice button until the red indicator appears in the window above the button.

To dispense ice:

1. Press button for the desired type of ice.
2. Press a sturdy glass against the ice dispenser lever. Hold the glass close to the dispenser opening so ice does not fall outside of the glass.
You do not need to apply a lot of pressure to the lever in order to activate the ice dispenser. Pressing hard will not make the ice dispenser faster or in greater quantities.
3. Remove the glass to stop dispensing.

NOTE:

The first few batches of ice cubes may have an off-taste. Throw this ice away.

Ice is dispensed from the ice maker bin in the freezer compartment. When the outside dispenser bar is pressed, a trapdoor opens between the ice bin and the dispenser. When the glass is taken away from the dispenser bar, a buzzing sound may be heard for a few seconds as the trapdoor closes.

The dispenser will not operate when the freezer compartment door is open.

Large amounts of ice cubes should be taken directly from the bin, not through the dispenser.

For crushed ice, cubes are crushed before being dispensed. This may cause a slight delay in dispensing crushed ice. Noise from the ice crusher is normal, and pieces of ice may vary in size.

When changing from crushed ice to ice cubes, a small quantity of crushed ice will be dispensed along with the first cubes.

After starting the appliance 3 to 4 hours are normally required to obtain the first ice cubes.

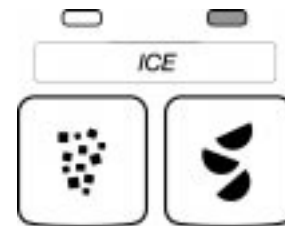

For cubed ice



For crushed ice





USE OF THE DISPENSER LIGHT AND DISPENSER LOCK (ON SOME MODELS)

The dispenser light

The dispenser area has a night light.

It can be turned on manually by pressing the button at the right hand side of the control panel.

The red indicator above the button will appear.

The dispenser lock

Your dispenser can be turned off for easy cleaning or to prevent accidental dispensing by small children and pets. To turn off the dispenser, press the LOCK button.

The indicator light will appear above the button and the ice and water dispensers will not work. To unlock the dispenser, press the UNLOCK button until the indicator light appears above.

Then continue to dispense ice or water as usual.

NOTE: The lock feature does not shut off power to the product, to the ice maker, or to the dispenser light. It simply deactivates the dispenser levers.



AUTOMATIC ICE MAKER

Useful hints on the automatic ice maker (Style I)

- The ON/OFF lever is a signal arm:
Down.... for making ice automatically.
Up..... to switch off the ice maker.

To turn the ice maker on/off: (Style II)

The ON/OFF switch is located on the top right side of the freezer compartment.

1. To turn the ice maker on, slide the control to the ON (left) position.

NOTE: Your ice maker has an automatic shut-off. The ice maker sensors will automatically stop ice production but the control will remain in the ON (left) position.

2. To manually turn the icemaker off, slide the control to the OFF (right) position.

To remove and replace ice bucket:

1. Place four fingers in bucket base opening and rest thumb on the release button.
 2. Holding the base of the bucket with both hands, depress the release button and lift the bucket up and out. It is not necessary to turn the ice maker control to the OFF (right) position. The ice maker will not produce ice without the bucket installed in the door.
- **Normal Ice Production** should produce approximately 7 to 9 batches of ice in a 24-hour period.

To care for ice storage bin or bucket:

1. Empty the ice container. Use warm water to melt the ice if necessary. **Never use anything sharp** to break up the ice in the bin or bucket. This can cause damage to the ice container and the dispenser mechanism.
2. Wash ice bin or bucket with a mild detergent, rinse well and dry thoroughly. Do not use harsh or abrasive cleaners or solvents.



Style I

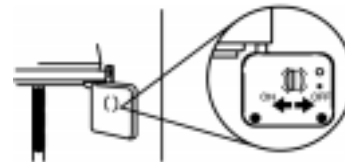

Style II





Removing the ice maker bin

Remove, empty, and clean the bin:

- if the ice dispenser has not been or will not be used for a week or more;
- if a power failure causes ice in the bin to melt and freeze together;
- if the ice dispenser is not used regularly.

To remove the bin

1. Pull the covering panel out from the bottom and slide it to the rear.
2. Lift the signal arm to the OFF position. Ice can still be dispensed, but no more will be made.
3. Lift the front of the bin and pull it out.
4. Empty the bin. Use warm or lukewarm water to melt the ice if necessary. Do not use sharp tools to break up the ice in the bin. This can damage the bin and the dispenser mechanism.
5. Wash following the instructions given under chapter "Maintenance and Cleaning". Rinse well. Do not use abrasive cleaners or solvents.
6. When putting the bin back, make sure it is pushed all the way in. Push the signal arm down to the ON position to restart ice cubes production.

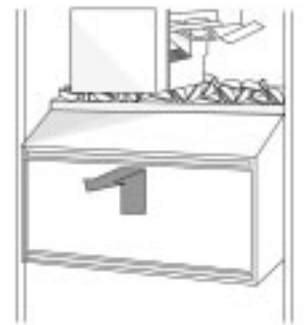
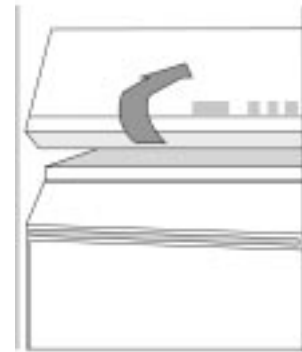

NOTE: Do not turn the ice maker on until it is connected to the water supply.

- It is normal for ice cubes to be attached by a corner. They will break apart easily.
- The ice maker will not operate until the freezer compartment is cold enough to make ice. This can take overnight.
- If ice is not being made fast enough and more ice is needed, set the refrigerator thermostat on a higher number. Wait a day and, if necessary, set the freezer compartment thermostat knob on "4/5."
- Good water quality is important for good ice quality. Water softener chemicals such as salt can damage the ice maker and lead to poor quality ice.

COMMON ICE MAKER PROBLEMS

PROBLEM	CAUSE	SOLUTION
The dispenser does not work.	The freezer compartment door is open. The ice bin is not properly installed.	Close the freezer compartment door. Make sure that the bin is pushed all the way in.
The ice dispenser stops working.	The dispenser has not been used for extended periods, causing the ice cubes to melt together. The ice dispenser bar has been held in for too long.	Shake the bin occasionally to keep cubes separate and to increase storage capacity. Throw old ice cubes away and make a new supply. Wait about 3 minutes for the dispenser motor to reset. Large amounts of ice should be taken from the bin, not through the dispenser.
Off-taste or odour in ice.	Ice absorbs airborne odours. Water quality. Food not properly wrapped. The ice bin and the freezer compartment may need cleaning. Plumbing to ice maker.	New ice should be made. Throw old ice away and make new supply. Store excess ice in a covered container. Water containing minerals may require a filter. Wrap food properly. Clean the ice bin and the freezer. Follow instructions for a proper water supply to ice maker. The first few batches of ice from a new ice maker may have an off-taste. Throw the ice away and make a new supply.

NOTE: Only use cubes from the ice maker.

MAINTENANCE AND CLEANING

Before carrying out any maintenance or cleaning, always unplug the appliance or disconnect the power supply.

Periodically clean the refrigerator and freezer compartments with a sponge dampened in a solution of lukewarm water and vinegar. Rinse and dry. Never use detergents or abrasives. Never clean refrigerator parts with flammable fluids. The fumes can create a fire hazard or explosion.

Clean the outside with a sponge dampened in lukewarm water. Dry with a soft cloth.

Periodically clean the defrost pan proceeding as follows:

- remove the front grille;
- remove the defrost pan;
- wash the defrost pan with warm water and mild detergent;
- rinse and dry;
- put the defrost pan back into place with the notched corner to the rear;
- make sure that the defrost drain tube is pointing into the pan;
- put the front grille back into place.

NOTE: The refrigeration system tubes are located near the defrost pan and can become hot. Periodically clean them with a vacuum cleaner.

Always disconnect the refrigerator from the power supply before replacing any light bulbs.

How to replace the refrigerator bulbs

- remove the bulb;
- replace it with one of the same type available only at our Service Centres or Retailers.

How to replace the freezer upper compartment bulb (on some models)

- remove the light shield by grabbing its upper central part;
- pull frontally and, at the same time, slightly turn the shield to one side;
- remove the bulb and replace it with one of the same type available only at our Service Centres or Retailers.

To put the light shield back into place:

- grab the upper central part of the light shield;
- insert the tabs of one side of the shield into the grooves;
- gently bend the light shield in the centre to insert the tabs on the other side.

How to replace the dispenser bulb (on some models)

- reach for the bulb in the dispenser recess;
- remove the bulb and replace it with one of the same type available only at our Service Centres or Retailers.

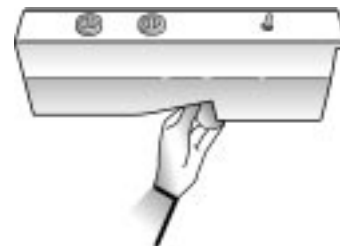

Dispenser light

VACATION

Short vacation

There is no need to disconnect the refrigerator from the power supply if you will be away for less than three weeks. Use up perishable food, freeze other food. If your appliance has an automatic ice maker:

1. Turn it off.
2. Shut off the water supply to the ice maker.
3. Empty the ice bin.

Long vacation

Remove all the food if you are going away for three weeks or more. If your appliance has an automatic ice maker, turn off the water supply to the ice maker at least a day before. When the last batch of ice cubes drops, turn off the ice maker. Unplug the refrigerator and clean it, rinse and dry. Fix some wooden or plastic wedges to the upper part of both doors with adhesive tape and leave the doors open enough for air to circulate inside both compartments. This will prevent odour and mould from setting in.

Moving

- Take out all removable parts, wrap them well, and fix them together with adhesive tape so that they will not come loose or shake.
- Tighten the front levelling screws.
- Close and fix both doors with adhesive tape and, again using adhesive tape, fix the power cable to the appliance.

Power failure

In case of power failure, call the local office of your Electricity Company and ask how long it is going to last.

1. Should the power failure last 24 hours or less, **keep both doors of the appliance closed**. This will allow the stored food to stay cold as long as possible.
2. Should the power failure last more than 24 hours, remove all frozen food and put it in a freezer with a key lock. If this type of freezer is not available and, likewise, no artificial ice packs are available, try to use up the food which is more easily perishable.
3. Bear in mind that a full freezer compartment will stay cold longer than a partially filled one.

Furthermore, a freezer full of frozen meat will stay cold longer than a freezer filled with pre-cooked food.

If the food still shows ice crystals, it is possible to refreeze it without running any risk; however, it will probably change taste and flavour. If the condition of the food is definitely poor and you feel like you would be running a risk by refreezing it, you must throw it away.



TROUBLESHOOTING GUIDE/SERVICE

Before calling for Service....

Performance problems often result from little things you can find and fix yourself without tools of any kind.

If your refrigerator will not work:

- Is the power cable plugged into a live socket with the proper voltage?
- Have you checked your home's fuses?
- Is the thermostat control in the off position?

If there are noises or vibrations:

Most of the noises are normal. Hard surfaces like the floor, walls, and cabinets can make the noises seem louder. The following describes the most common types of noises and what may be making them:

• **Slight hum**

You may be hearing the refrigerator's fan motor and moving air.

• **Clicking noises**

The thermostat clicks when the refrigerator stops running. It also makes a sound when the refrigerator starts. The defrost timer clicks when the defrost cycle starts and stops.

• **Water noises**

When the refrigerator stops running, you may hear a gurgling noise in the piping for a few minutes. You may also hear the defrost water running into the defrost water pan.

• **Ice maker noises**

Since your appliance has an ice maker, you may hear buzzing (from the water valve), trickling water and the clatter of the ice falling into the bin.

If your ice maker will not work:

- Has the freezer had enough time to become cold? With a new refrigerator this may take overnight.
- Is the lever in the down position (ON)?
- Is the water turned on? Is water getting to the ice maker?
- Is there a water filter installed on the refrigerator?

This filter may be clogged or installed incorrectly. First, check the filter installation instructions to ensure that the filter was installed correctly and is not clogged. If installation or clogging is not a problem, call a qualified person or a technician.

If there is water in the defrost pan:

- This is normal in hot, damp weather. The pan can even be half full. Make sure the refrigerator is level so that the water does not overflow.

If the edges of the refrigerator cabinet, which come in contact with the door gasket, are warm to the touch:

- This is normal in hot weather when the compressor is running.

If the light does not work:

- Have you checked your home's fuses?
- Is the power cable plugged into a live socket with the proper voltage?
- Has the light bulb burnt out?

In case of burned out bulbs:

1. Always pull the plug out of the socket;
2. Reach for the bulb behind the control panel;
3. Remove the bulb;
4. Replace it with one of the same type available only at our Service Centres or Retailers.

If the motor seems to run too much:

- Is the condenser free of dust and lint?
- Are the doors properly closed?
- Are the door gaskets properly sealed?
- On hot days or if the room is warm, the motor naturally runs longer.

If the door has been opened a lot or if a large amount of food has been stored, the motor will run longer to cool down the interior.



TROUBLESHOOTING GUIDE/SERVICE

Remember:

Motor running time depends on different things: number of door openings, amount of food stored, temperature of the room, setting of the temperature controls.

If you have followed the above checks and your appliance still does not work properly, get in touch with the After Sale Service. State clearly what is wrong and the type and serial number of your appliance (these data are on the rating plate).

If the refrigerator temperature is too warm

- Are the refrigerator controls adjusted correctly?
- Has a large amount of food been added to the refrigerator or freezer?
- Check to see that the doors are not opened too often.
- Check to see that the doors are closing properly.
- Make sure that air vents are not blocked in the compartment. This will prevent the movement of cold air.

If there is moisture build-up

- Check to see if that air vents are not blocked in the compartment. This will prevent proper air circulation.
- Make sure that the food is properly packaged. Wipe all damp food containers before placing them in the refrigerator.
- Check to see that the doors are not opened too often. When the door is opened, humidity from the room air enters the refrigerator. The more often the door is opened, the faster humidity builds up, especially when the room itself is very humid.
- If the room is very humid, it is normal for moisture to build up inside the refrigerator.
- It is normal for droplets of water to form on the back wall after the refrigerator self-defrosts.

If the doors are not closing and opening properly

- Check that food packages are not blocking the door.
- Check that the pans, shelves, drawers or the ice maker are not out of position.
- Check that the door gaskets are not dirty or sticky.
- Make sure that the refrigerator is level.

To replace the power cable:

You must ask our After Sale Service to replace the power cable.



WATER FILTRATION AND MONITORING SYSTEM (ON SOME MODELS)

The water filter indicator light

The water filter indicator light will help you know when to change your water filter cartridge. The light is located at the top of the refrigerator compartment. The light will change from green to yellow. This tells you that it is almost time to change the water filter cartridge (90% of the filter life has been used). It is recommended that you replace the water filter cartridge when the water filter indicator light changes to red OR water flow to your water dispenser or ice maker decreases noticeably. (See "Changing a water filter cartridge" later in this section).

NOTE: Do not use with water that is microbiologically unsafe or of unknown quality without adequate disinfection before or after the system.

After changing the water filter cartridge, reset the water filter indicator light by pressing the light switch 5 times within 10 seconds. The indicator light will change from red to green when the system is reset.

Changing a water filter cartridge

The water filter is located below the freezer compartment door.

- 1 Locate the water filter cartridge cap in the front base grille below the freezer compartment door. Rotate the cap counterclockwise to a vertical position and pull the cap and filter cartridge out through the base grille.

NOTE: There will be water in the cartridge. Some spilling may occur.

- 2 Remove the cartridge cap by sliding it off the end of the old cartridge. The cap will slide to the left or right. DO NOT DISCARD THE CAP.
- 3 Take the new cartridge out of its packaging and remove protective cover from o-rings.
- 4 Slide the cartridge cap onto the new cartridge as shown.
- 5 With cartridge cap in the vertical position, push the new filter cartridge into the base grille until it stops. Rotate the cartridge cap clockwise to a horizontal position.
- 6 RUN WATER THROUGH THE DISPENSER UNTIL THE WATER RUNS CLEAR (about 9-14 litres or 6-7 minutes). This will clean the system and clear air from the lines. Additional flushing may be required in some households.

NOTE: As air is cleared from the system, water may spurt out of the dispenser.

Filter Indicator Reset

Style I



Style II



Signal

Green = Good filter
Yellow = Order filter
Red = Change filter



①

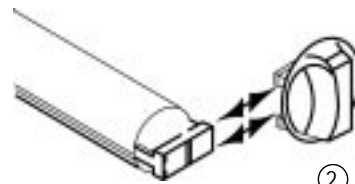

②



③



④



⑤

WATER FILTRATION AND MONITORING SYSTEM (ON SOME MODELS)

Using the dispenser without the water filter

You can run the dispenser without a water filter cartridge. Your water will not be filtered. If you run the dispenser without a water filter cartridge, keep the cartridge cap and replace it in the base grille for future use.

1. Remove the water filter cartridge (See "Changing a water filter cartridge" earlier in this section.) Then slide the cartridge cap off the end of the filter cartridge. **DO NOT DISCARD THE CAP.**
2. With the cartridge cap in the vertical position, insert the cap into the base grille until it stops.
3. Rotate the cartridge cap to a horizontal position.

NOTE: The cartridge cap may not be even with the base grille.

Ordering replacement filters

To order more water filter cartridges, please contact your authorized Whirlpool dealer.

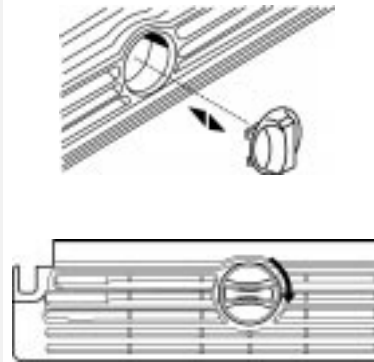

WATER CONNECTION (FOR ALL MODELS GREATER THAN 60 cm DEEP)

- We recommend that installation is carried out by a qualified plumber or by the After-sales Service nearest to the sales outlet where the appliance was purchased.
- Disconnect the electrical supply to the refrigerator prior to installing the ice maker water line.
- The appliance is supplied with 2 metres of coiled water tubing for connecting the ice maker to the water supply.
- First remove the protective rubber cap, then connect the smallest end of the coiled tubing (1) to the water connector (2). Do not over-tighten the connection.
- Connect the large connector (3) to the domestic water supply (4).
- The appliance is pre-set for operation at pressures between 1.5 and 8 atm (20 and 120 psi).
- Open the water tap. Check for and correct any leaks.
- The appliance does not require any adjustment or the use of a water drain.

NOTE: The water connection should be carried out in compliance with local regulations.

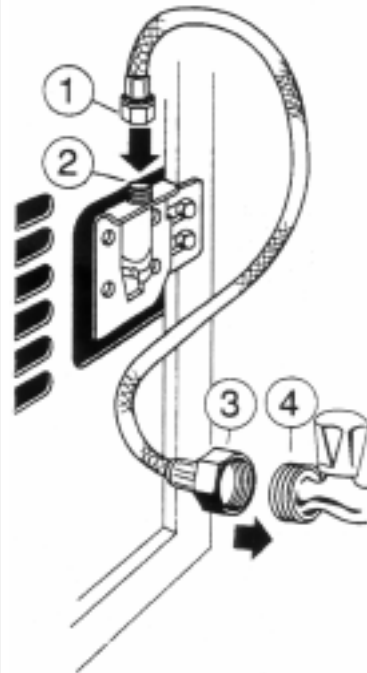

WATER CONNECTION (FOR 60 cm DEEP MODELS ONLY)

- We recommend that the installation is carried out by a qualified plumber or by service.
 - Disconnect electrical supply to refrigerator prior to installing the ice maker water line.
 - The appliance is supplied with a gray water tube, 2330 mm long, already attached to the back of the refrigerator and is provided with a transition connector for connecting the ice maker to the water supply.
 - Remove the shipping tape from the gray coiled water tubing on the rear of the refrigerator.
 - Remove the protective cap from the end of the gray water tubing.
 - Connect the gray water tube (1) to the transition connector (2). Do not over-tighten, finger tighten and then 1 to 2 additional turns should be adequate.
 - Connect the transition connector (2) to the household water supply (3).
 - The appliance is preset for operation at pressures between 1.5 and 8 atm (20 and 120 psi).
 - Open the water Tap. Check for and correct leaks.
 - The appliance doesn't require any adjustment nor water drain.
- NOTE:** We suggest the water connection is carried out in compliance with local regulations.

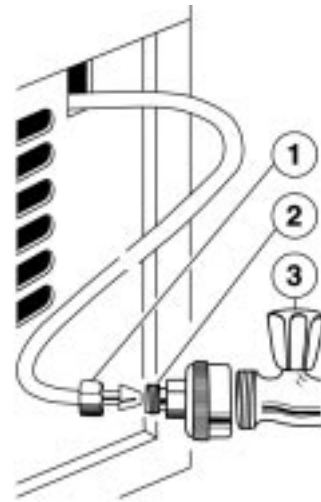

DISPOSAL OF YOUR OLD REFRIGERATOR

- Entrapment and suffocation are not problems of the past. To a child, a junked or abandoned refrigerator can be dangerous -- even if only left unattended for a few days. Before you dispose of your refrigerator or freezer:
- Take off the doors.
 - Leave the shelves in place so that children may not easily climb inside.

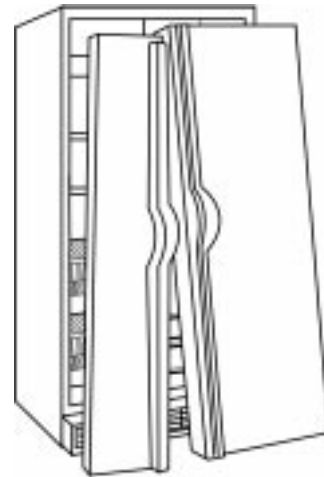

ELECTRICAL CONNECTION

1) For Great Britain only

Warning - this appliance must be earthed

Fuse replacement

If the mains lead of this appliance is fitted with a BS 1363A 13amp fused plug, to change a fuse in this type of plug use an A.S.T.A. approved fuse to BS 1362 type and proceed as follows:

1. Remove the fuse cover (A) and fuse (B).
2. Fit replacement 13A fuse into fuse cover.
3. Refit both into plug.

Important:

The fuse cover must be refitted when changing a fuse and if the fuse cover is lost the plug must not be used until a correct replacement is fitted.

Correct replacement are identified by the colour insert or the colour embossed in words on the base of the plug.

Replacement fuse covers are available from your local electrical store.

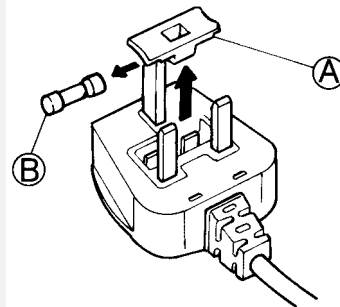

2) For the Republic of Ireland only

The information given in respect of Great Britain will frequently apply, but a third type of plug and socket is also used, the 2-pin, side earth type.

3) Socket outlet / plug (valid for both countries)

If the fitted plug is not suitable for your socket outlet, please contact Whirlpool Service for further instruction. Please do not attempt to change plug yourself. This procedure needs to be carried out by a qualified Whirlpool technician in compliance with the manufactures instructions and current standard safety regulations.