



INSTRUCTIONS FOR USE

BEFORE USING THE APPLIANCE

SAFEGUARDING THE ENVIRONMENT

**PRECAUTIONS AND GENERAL
RECOMMENDATIONS**

HOW TO USE THE FREEZER

CARE AND MAINTENANCE

TROUBLESHOOTING GUIDE

AFTER SALES SERVICE

INSTALLATION

ELECTRICAL CONNECTION

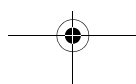
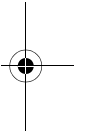
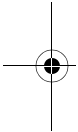

BEFORE USING THE APPLIANCE

- Your new appliance is designed exclusively for domestic use

For best use of your appliance, carefully read the user's handbook which contains a description of the appliance and advice on storing and preserving food.

Keep this handbook for future consultation.

- After unpacking, make sure that the appliance is undamaged and that the door closes perfectly tight. Any damage must be reported to your dealer within 24 hours after delivery of the appliance.
- Wait at least two hours before switching the appliance on in order to ensure the refrigerant circuit is fully efficient.
- Installation of the appliance and electrical connections must be carried out by a qualified electrician, in accordance with the manufacturer's instructions and local safety regulations
- Clean the inside of the appliance before using it.

SAFEGUARDING THE ENVIRONMENT

1. Packing

The packaging material is 100% recyclable and carries the recycling symbol. Follow local regulations for scrapping. Keep the packaging materials (plastic bags, polystyrene parts, etc.) out of reach of children, as they are potentially dangerous.

2. Scrapping

The appliance is manufactured using recyclable material.

This appliance is marked according to the European directive 2002/96/EC on Waste Electrical and Electronic Equipment (WEEE). By making sure this appliance is disposed of correctly, the user will help prevent potentially negative consequences for the environment and the health of persons.

The symbol  on the appliance, or on the accompanying documents, indicates that this appliance should not be treated as domestic waste but must be taken to a suitable collection point for the recycling of electrical and electronic equipment.

Before scrapping, make the appliance unusable by cutting off the power cable and removing the doors and shelves so that children cannot easily climb inside the appliance.

Disposal must be carried out in accordance with local environmental regulations for waste disposal. Deliver the appliance immediately to an authorized dump; do not leave it unattended even for a few days, since it is potentially dangerous for children. For more information regarding the treatment, recovery and recycling of this appliance, contact your local office, the domestic waste collection service or the shop where you purchased the product.

Information:

This appliance does not contain CFCs (the refrigerant circuit contains R134a) or HFCs (the refrigerant circuit contains R600a) (see the rating plate inside the appliance).

Appliances with Isobutane (R600a): isobutane is a naturally occurring, low environmental impact gas. Caution is required, however, because isobutane is flammable. Therefore, ensure that the pipelines of the refrigerant circuit do not get damaged.

Declaration of conformity

- This appliance is designed to store food and is manufactured in conformity with European Directive 90/128/EEC, 02/72/EEC and Regulation (EC) No. 1935/2004



- This product has been designed, manufactured and retailed in compliance with:
 - the safety objectives of the Low Voltage Directive 73/23/EEC;
 - the protection requirements of the "EMC" Directive 89/336/EEC, amended by Directive 93/68/EEC.
- The electrical safety of the appliance can only be guaranteed if the product is connected to an approved earth connection.



PRECAUTIONS AND GENERAL RECOMMENDATIONS

- Use the refrigerator compartment only for the storage of fresh food and the freezer compartment only for the storage of frozen food, the freezing of fresh food, and to make ice cubes.
- During installation, make sure the appliance does not damage the power cable.
- Do not store glass containers with liquids in the freezer since they may burst.
- Do not eat ice cubes or ice lollies immediately after taking them out of the freezer since they may cause cold burns.
- Before servicing or cleaning the appliance, unplug it from the mains or disconnect the electrical power supply.
- Make sure that the appliance is not near a heat source.
- Do not store or use petrol, gas or flammable liquids in the vicinity of the appliance or other electrical appliances. The fumes can create a fire hazard or explosion.
- To ensure adequate ventilation, leave a space on both sides and above the appliance and follow the installation instructions.
- Keep the appliance ventilation openings free.
- All appliances equipped with an ice maker or water dispenser must be connected to a mains water supply that delivers potable water only (with water pressure between 1.7 and 8.1 bar (25 and 117 PSI)). Ice makers and/or water dispensers not directly connected to a mains water supply must be filled with potable water only.
- Install and level the appliance on a floor strong enough to take its weight and in an area suitable for its size and use.
- For the water connection, use the pipe supplied with the new appliance and do not use that of the previous appliance.
- The appliance must be handled and installed by two or more persons.

- Place the appliance in a dry and well-ventilated place. The appliance is set for operation at specific ambient temperature ranges, according to the climatic class indicated on the data plate: The appliance may not work properly if it is left for a long period at a temperature above or below the indicated range.

Climatic class	Amb. T. (°C)	Amb. T. (°F)
SN	From 10 to 32	From 50 to 90
N	From 16 to 32	From 61 to 90
ST	From 18 to 38	From 64 to 100
T	From 18 to 43	From 64 to 110

- Be careful not to damage the floors when you move the appliance (e.g. parquet flooring).
- Do not use mechanical, electric or chemical means other than those recommended by the Manufacturer to speed up the defrost process.
- Do not damage the refrigerator's refrigerant circuit pipes.
- Do not use or place electrical appliances inside the compartments if they are not of the type expressly authorised by the Manufacturer.
- This appliance is not designed for use by young children or the infirm without supervision.
- To avoid the risk of children being trapped and therefore suffocating, do not allow them to play or hide inside the appliance.
- Power cable modification or replacement must only be carried out by qualified personnel.
- Do not use single/multiple adapters or extension cables.
- It must be possible to disconnect the appliance from the mains by unplugging it or by means of a two-pole switch fitted upline of the socket.
- Ensure that the voltage indicated on the appliance data plate corresponds to the domestic supply voltage
- Do not swallow the contents (non-toxic) of the ice packs (if provided).
- The Manufacturer declines any liability if the above recommendations and precautions are not respected.

HOW TO USE THE FREEZER

The freezer can be used for storing already frozen food and for freezing fresh food.

Switching on the freezer for the first time

- There is no need to set the freezer temperature on the thermostat because the appliance is already factory set.
- Plug in the appliance.
- The alarm signal activates, indicating that the freezer has not yet reached a sufficiently cold temperature for storage of foodstuffs.
- Only place food in the freezer once the alarm signal has deactivated (for further details, see the enclosed product sheet).

Temperature Adjustment

For temperature adjustment, see the enclosed product sheet.

Note:

Ambient air temperature, the frequency of door opening and the position of the appliance can affect the freezer internal temperature.

Take these factors into consideration when setting the thermostat knobs.

"6th Sense" function

The 6th Sense function, if present, is automatically activated in the following cases:

Door opening

The function activates when door opening causes the internal temperature to increase to values that do not ensure safe storage of food and remains active until optimal storage conditions have been restored.

Placing fresh food in the freezer

The function activates when fresh food is placed in the freezer and remains active until optimal freezing conditions are reached so as to ensure the best freezing quality with the lowest power consumption.

NOTE: Besides the quantity of food loaded into the freezer, ambient temperature and the quantity of food already inside the freezer affect the duration of the 6th Sense function. Therefore significant duration variations are quite normal.

Freezing

The amount of fresh food (in kg) that can be frozen in 24 hours is indicated on the appliance data plate.

For optimum appliance performance, press the fast freeze button (until the yellow LED lights up) 24 hours before placing fresh food in the freezer.

After placing fresh food in the freezer, 24 hours on fast freeze function is generally sufficient; After 24 hours, deactivate the fast freeze function

Attention:

In order to save energy, when freezing small amounts of food, the fast freeze function can be deactivated after a few hours.

If the 6th Sense function is present, appliance operation is controlled automatically and no operation is required (see chapter "6th Sense" function)



Tips for freezing and storing fresh food.

- Before freezing, wrap and seal fresh food in: aluminium foil, cling film, air and water-tight plastic bags, polythene containers with lids or freezer containers suitable for freezing fresh food.
- Food must be fresh, mature and of prime quality in order to obtain high quality frozen food.
- Fresh vegetables and fruit should preferably be frozen as soon as they are picked to maintain the full original nutritional value, consistency, colour and flavour.

Some meat, especially game, should be hung before it is frozen.

Note:

- Always leave hot food to cool before placing in the freezer.
- Eat fully or partially defrosted foods immediately. Do not refreeze unless the food is cooked after it has thawed. Once cooked, the thawed food can be refrozen.

Freezing and storing fresh food

- Place foods to be frozen in the baskets.
- Place the ice packs (if supplied) above the food stored in the top compartment.
- In models with ice packs, in the event of a power failure, place the ice pack/s above the food stored in the top compartment, in order to optimise the rising time and therefore maintain correct food preservation.

Important:

The table alongside shows the recommended maximum storage time for frozen fresh foods.

Declared performance refers to appliance operation without ice packs, with the exception of the rising time.

Classification of frozen foods

Put the frozen products into the freezer and classify them.

The storage date should be indicated on the packs, to allow use within expiry dates.

Advice for storing frozen food

When purchasing frozen food products:

- Ensure that the packaging is not damaged (frozen food in damaged packaging may have deteriorated). If the package is swollen or has damp patches, it may not have been stored under optimal conditions and defrosting may have already begun.
- When shopping, leave frozen food purchases until last and transport the products in a thermally insulated cool bag.
- Once at home, place the frozen foods immediately in the freezer.
- If food has defrosted even partially, do not re-freeze it. Consume within 24 hours.
- Avoid, or reduce temperature variations to the minimum. Respect the best-before date on the package.
- Always observe the storage information on the package.



MONTHS	FOOD
1-3	
4-7	
8-12	



Removing the baskets

- Pull the baskets out fully, then lift them up slightly in order to remove.

Drawers (except the bottom drawer) may be removed in order to obtain increased storage space (**Fig. 1**)

Ensure that the load does not exceed the limit (if present) indicated on the side walls of the appliance.

Please follow the storage times given on the frozen food packages.

Making ice cubes

- Fill the ice cube tray 2/3 full and place it in the special freezer compartment.
- Do not use sharp or pointed instruments to detach the tray if it is stuck to the bottom of the freezer.
- Bend the ice tray slightly to remove the cubes.

Note:

The freezer door will not re-open easily immediately after closing (except for the models with specific valve).

Wait a few minutes before opening again in order to allow for compensation of the vacuum created.

Intelligent ice system with feeder

Some models are equipped with an ice system including a feeder, ice cube trays with removal device and ice bin. Thanks to this system, it is easy to fill the ice cube trays with water, remove the ice cubes and store them.

The feeder allows you to easily fill the trays with water without having to remove them from the freezer and without spilling water on the kitchen floor.

Filling the trays with water:

- before filling the trays, clean them as described in the cleaning section.
- To remove the feeder, pull it towards you.
- Fill the feeder with water without resting it on a surface, then refit it on its support. The water will automatically fill the ice cube trays.
- Wait for a few hours for the ice to be ready, then turn the knobs to extract the ice cubes. The ice cubes will fall directly into the ice bin.

Attention:

- make sure there are no ice cubes in the tray before refitting the feeder.
- Before refitting the feeder, make sure there is no ice on the springs; if there is, remove it under running water.
- The removable parts of the ice system may be taken out in order to obtain increased storage space.



Fig. 1

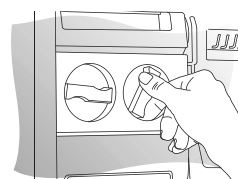
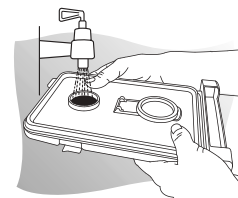
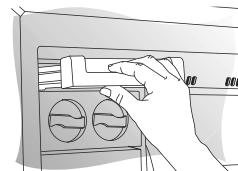
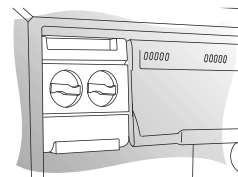

CARE AND MAINTENANCE

Before any cleaning or maintenance operation, unplug the appliance from the mains or disconnect the electrical power supply.

For electronic models, first press the on/off button and then unplug the the appliance.

Periodically clean the condenser at the rear of the appliance with a vacuum cleaner or brush.

Periodically clean the inside of the compartment with a sponge dampened in warm water and/or neutral detergent. Rinse and dry with a soft cloth. Do not use abrasive products

Long vacation

- Empty the freezer.
- Disconnect the freezer from the mains power supply.
- Defrost and clean.

Leave the door open to prevent formation of unpleasant odours and to eliminate any dampness

Note: for electronic models, first insert the power plug into the mains socket and then press the on/off button to switch on the appliance.



TROUBLESHOOTING GUIDE

1. The appliance is not working.

- Is there a power failure?
- Is the main power switch on?
- Has the fuse blown?
- Is the thermostat setting correct?
- Was the appliance switched on correctly?

2. Excessive frost build-up.

- Has the defrost water drain been positioned correctly?
- Is the door shut properly?

3. The yellow, red and green LEDs do not light up. Perform the checks for point 1, and then:

- Contact After Sales Service.

Notes:

- **The front edge of the appliance may be hot. This prevents the formation of condensation and is not a defect.**
- **Gurgling and hissing noises due to expansion in the refrigerant circuit are normal.**

AFTER SALES SERVICE

Before contacting After Sales Service:

1. See if you can solve the problem yourself with the help of the Troubleshooting guide.
2. Switch the appliance on again to see if the problem has been solved. If it has not, disconnect the appliance from the power supply and wait for about an hour before switching on again.
3. If the problem persists after this course of action, contact After-sales Service.
Specify:
 - the nature of the fault,
 - the model,

- the Service number (the number after the word SERVICE on the rating plate on the inside of the appliance),
- your full address,
- your telephone number and area code.

SERVICE 0000 000 00000



Note:

The direction of door opening can be changed. If this operation is performed by After-sales Service it is not covered by the warranty. The door cannot be reversed on models with front handle.

INSTALLATION

- Install the freezer away from heat sources. Installation in a hot environment, direct exposure to the sun or installation near heat sources (heaters, radiators, cookers) will increase power consumption and should therefore be avoided.
- If this is not possible, the following minimum distances must be respected:
 - 30 cm from coal or paraffin stoves;
 - 3 cm from electric and/or gas stoves.
- Install the appliance in a dry, well-ventilated place.
- Clean the interior (see "care and maintenance").
- Fit the accessories supplied (Fig. 1 and 2).

Electrical connection

- **Electrical connections must be made in accordance with local regulations.**
- Voltage and power consumption are indicated on the rating plate inside the appliance.
- **Regulations require that the appliance is earthed. The Manufacturer declines all liabilities for injury to persons or animals or damage to property resulting from failure to observe these regulations.**
- If the plug and socket are not of the same type, have the socket replaced by a qualified electrician.
- Do not use extension leads or adapters.

Disconnecting the appliance

Electrical disconnection must be possible either by unplugging the appliance or by means of a double-pole switch located upline from the socket.

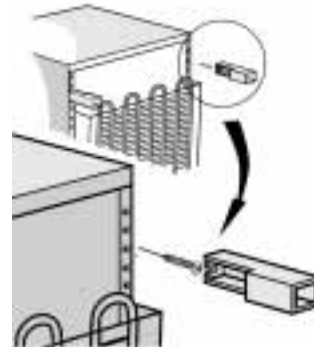

Fig. 1



Fig. 2

ELECTRICAL CONNECTION

1) For Great Britain only

Warning - this appliance must be earthed

Fuse replacement

If the mains lead of this appliance is fitted with a BS 1363A 13amp fused plug, to change a fuse in this type of plug use an A.S.T.A. approved fuse to BS 1362 type and proceed as follows:

1. Remove the fuse cover (A) and fuse (B).
2. Fit replacement 13A fuse into fuse cover.
3. Refit both into plug.

Important:

The fuse cover must be refitted when changing a fuse and if the fuse cover is lost the plug must not be used until a correct replacement is fitted.

Correct replacement are identified by the colour insert or the colour embossed in words on the base of the plug.

Replacement fuse covers are available from your local electrical store.

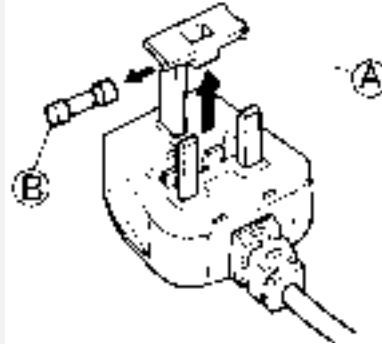

2) For the Republic of Ireland only

The information given in respect of Great Britain will frequently apply, but a third type of plug and socket is also used, the 2-pin, side earth type.

3) Socket outlet / plug (valid for both countries)

If the fitted plug is not suitable for your socket outlet, please contact Whirlpool Service for further instruction. Please do not attempt to change plug yourself. This procedure needs to be carried out by a qualified Whirlpool technician in compliance with the manufactures instructions and current standard safety regulations.